







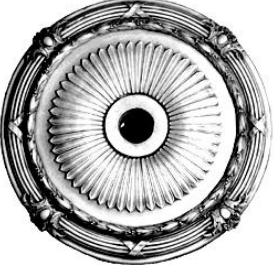

J.P. Weaver, Co.

Plaster Mould Reference

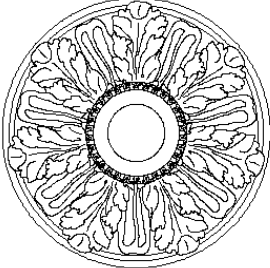

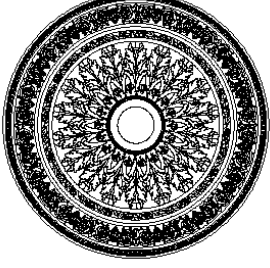
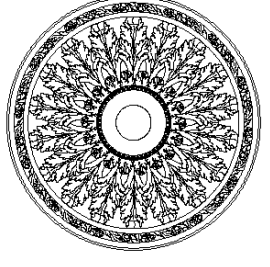
PLAS MOLD #	PICTURE	LEN.	HT.	PROJ.	UNIT	WEIGHT
PLAS 816M		78.5"	4-1/4"	4-1/8"	EACH	20 LBS
PLAS 818		27-5/8"			EACH	28 LBS
PLAS 825		28"			EACH	30 LBS
PLAS 826		42"			EACH	60 LBS

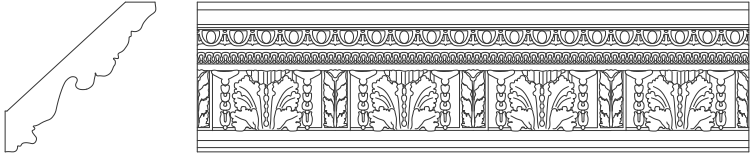
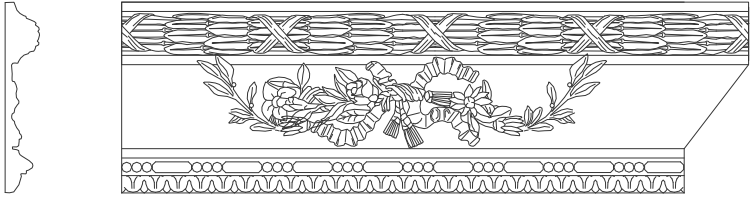
PLAS MOLD #	PICTURE	LEN.	HT.	PROJ.	UNIT	WEIGHT
PLAS 826A		19-3/8"			EACH	26 LBS
PLAS 826B		25-1/2"			EACH	30 LBS
PLAS 831		60"			EACH	135 LBS
PLAS 831B		46-3/4"			EACH	70 LBS

PLAS MOLD #	PICTURE	LEN.	HT.	PROJ.	UNIT	WEIGHT
PLAS 834		48"	12"		EACH	120 LBS
FIREPLACE SURROUND PLAS 838					EACH	180 LBS
`PLAS 839M		86"	6-3/4"	6-3/4"	EACH	45 LBS
PLAS 843		62"	10-1/4"	1-7/8"	EACH	

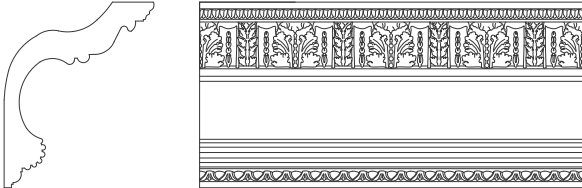
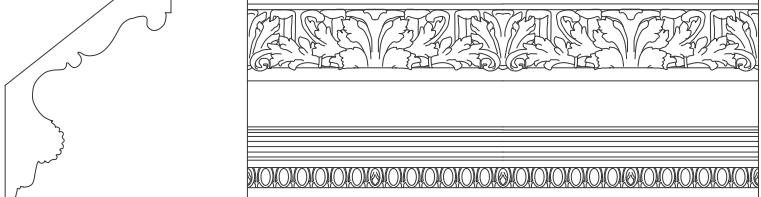
PLAS MOLD #	PICTURE	LEN.	HT.	PROJ.	UNIT	WEIGHT
PLAS 845					EACH	35 LBS
PLAS 845B					EACH	40 LBS
PLAS 846					EACH	45 LBS
PLAS 847					EACH	35 LBS

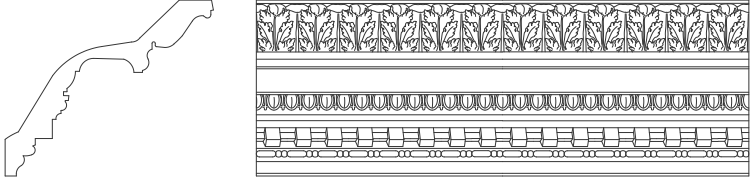
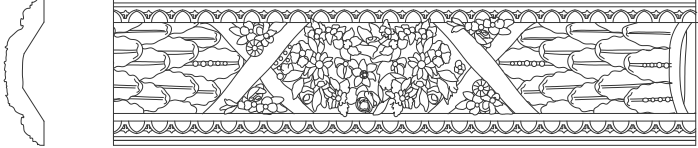

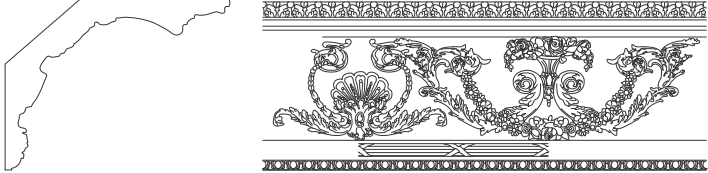
PLAS MOLD #	PICTURE	LEN.	HT.	PROJ.	UNIT	WEIGHT
PLAS 848					EACH	25 LBS
PLAS 849R		29"			EACH	30 LBS
PLAS 853		85.5"	13"	10-1/2"	EACH	70 LBS
PLAS 854		79"	12"	10"	EACH	70 LBS

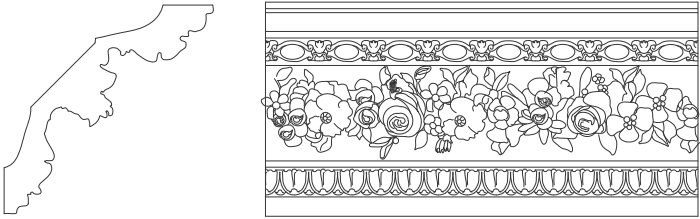
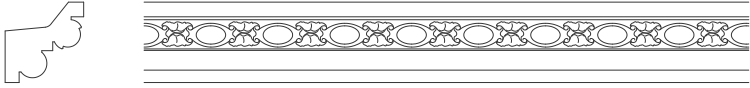
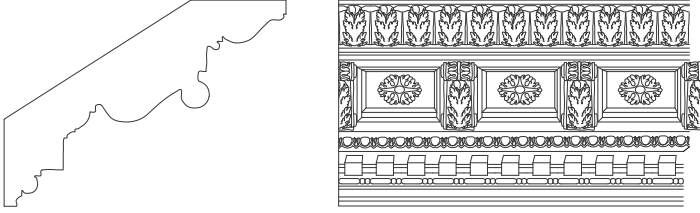
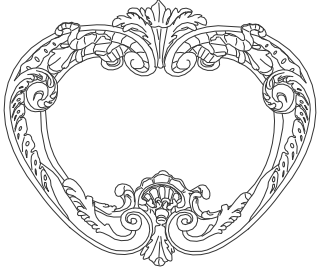

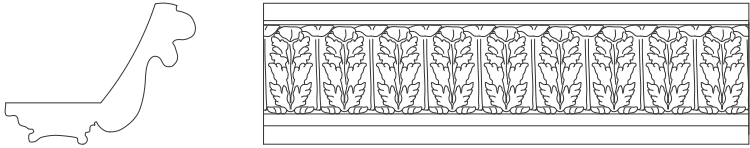
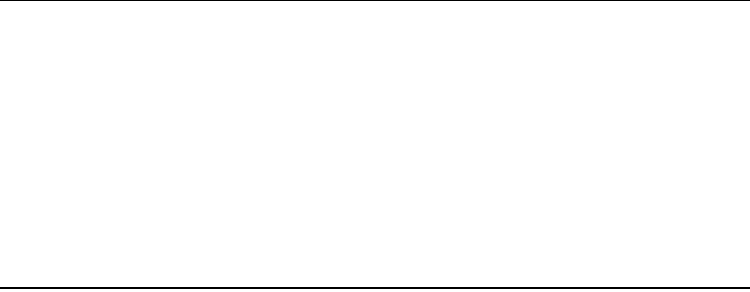
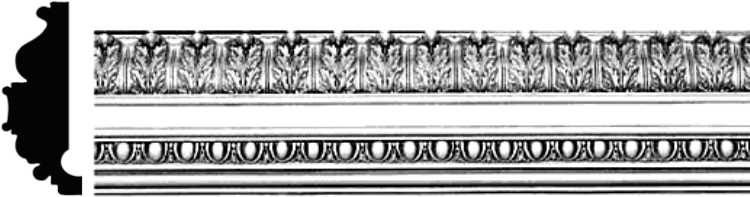
PLAS MOLD #	PICTURE	LEN.	HT.	PROJ.	UNIT	WEIGHT
PLAS 855		84.5"	10"	11-3/4"	EACH	55 LBS
PLAS 856		89"	10-1/4"	3"	EACH	
PLAS 857		82"	7-3/8"	3-1/8"	EACH	32 LBS
PLAS 858		78"	12"	15-3/8"	EACH	70 LBS

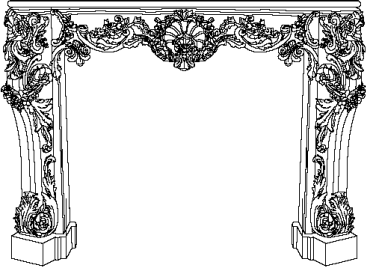
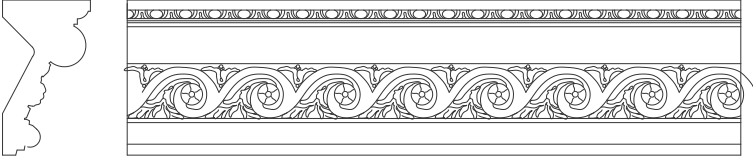
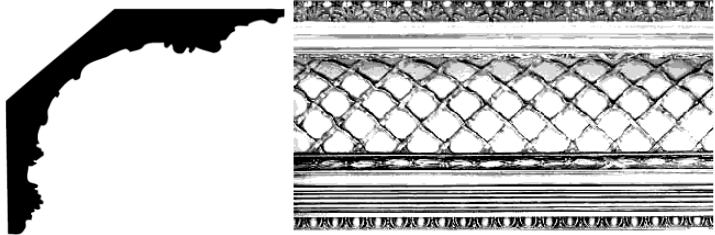
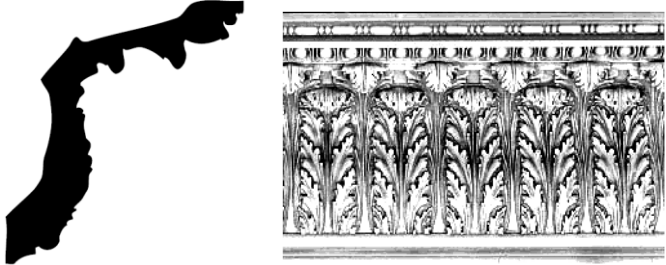

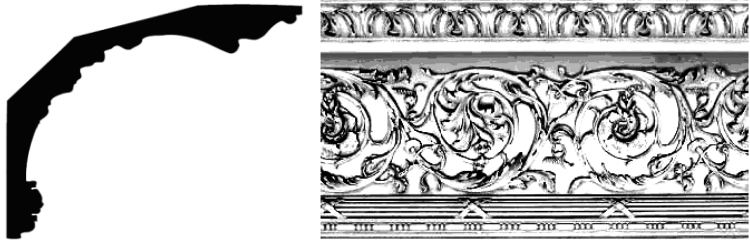
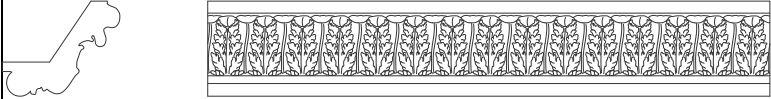
PLAS MOLD #	PICTURE	LEN.	HT.	PROJ.	UNIT	WEIGHT
PLAS 859		90"	9-1/2"	9-1/2"	EACH	70 LBS
PLAS 859B		89"	2-13/16"	2-3/4"	EACH	13 LBS
PLAS 860		71"	9"	12-1/4"	EACH	72 LBS
PLAS 861		24"	12"	15"	EACH	20 LBS

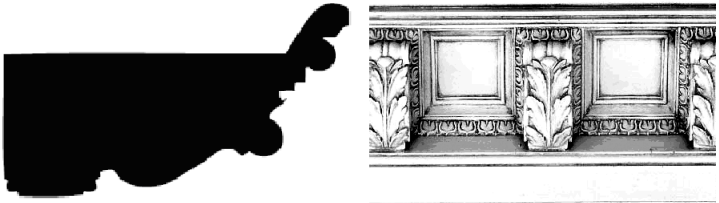

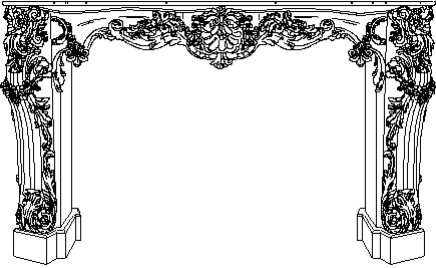
PLAS MOLD #	PICTURE	LEN.	HT.	PROJ.	UNIT	WEIGHT
PLAS 862		78"	8-3/4"	9-1/2"	EACH	42 LBS
PLAS 863		90"	4-1/2"	6-1/8"	EACH	24 LBS
PLAS 864		96"	5"	2"	EACH	20 LBS
PLAS 865		96"	7"	2-3/8"	EACH	36 LBS

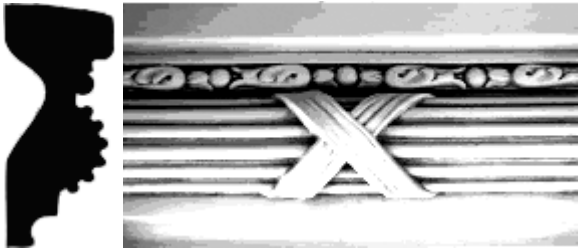
PLAS MOLD #	PICTURE	LEN.	HT.	PROJ.	UNIT	WEIGHT
PLAS 866					EACH	425 LBS
PLAS 867		88"	6-3/4"	3-5/8"	EACH	40 LBS
PLAS 868		76.5"	12"	15"	EACH	70 LBS
PLAS 869		81.5"	11"	10"	EACH	60 LBS

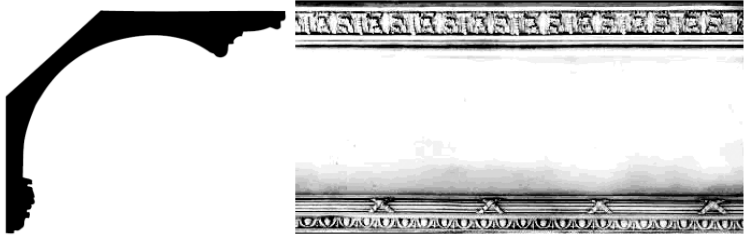
PLAS MOLD #	PICTURE	LEN.	HT.	PROJ.	UNIT	WEIGHT
PLAS 870	 <p>The image shows a black silhouette of a curved plaster mold on the left. To its right is a photograph of the actual plaster mold, which features a highly detailed, symmetrical floral and scrollwork design.</p>	66"	12"	15-1/8"	EACH	70 LBS
PLAS 871	 <p>The image shows a black silhouette of a plaster mold on the left. To its right is a photograph of the actual plaster mold, which features a repeating pattern of stylized floral motifs.</p>	92"	4-1/8"	5"	EACH	24 LBS
PLAS 873	 <p>The image shows a black silhouette of a plaster mold on the left. To its right is a photograph of the actual plaster mold, which features a wide, horizontal band of intricate floral and scrollwork designs.</p>	72"	12"	4-5/8"	EACH	
PLAS 874	 <p>The image shows a black silhouette of a plaster mold on the left. To its right is a photograph of the actual plaster mold, which features a complex design with two central rectangular panels flanked by ornate scrollwork and floral motifs.</p>	77"	4-3/8"	6-5/8"	EACH	40 LBS

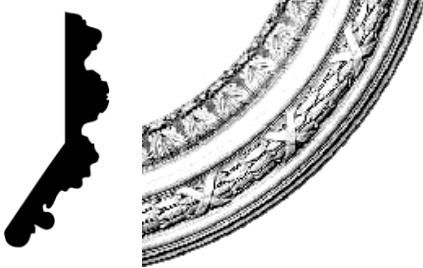
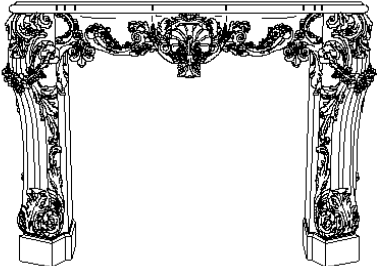
PLAS MOLD #	PICTURE	LEN.	HT.	PROJ.	UNIT	WEIGHT
PLAS 875					EACH	500 LBS
PLAS 877		93"	4-3/4"	5"	EACH	30 LBS
PLAS 878		73"	5-1/4"	3-1/2"	EACH	30 LBS
PLAS 879		94"	6-5/8"	3"	EACH	45 LBS

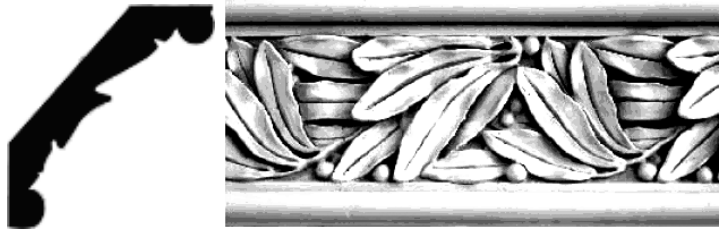
PLAS MOLD #	PICTURE	LEN.	HT.	PROJ.	UNIT	WEIGHT
PLAS 880		78"	12"	15-3/8"	EACH	65 LBS
PLAS 882		80"	6-3/16"	8-1/4"	EACH	38 LBS
PLAS 883		84"	10"	4-1/2"	EACH	54 LBS
PLAS 884					EACH	384 LBS

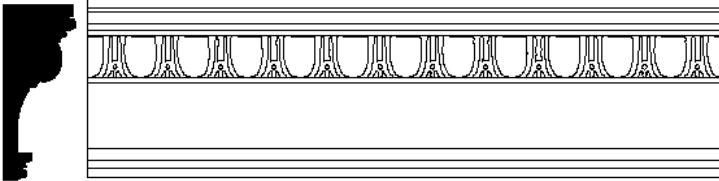
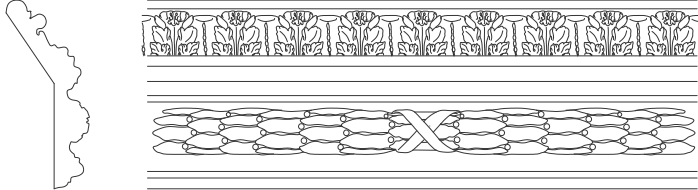

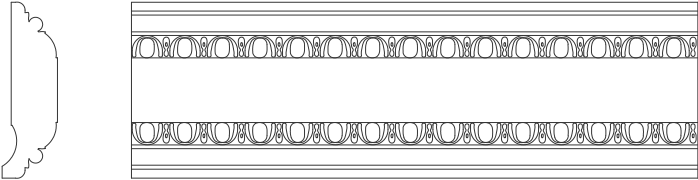
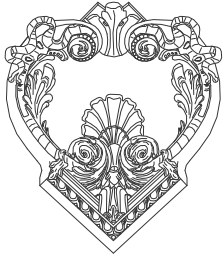
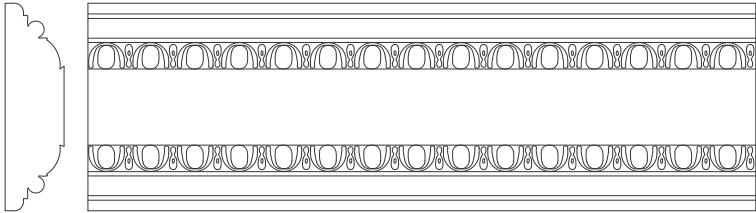
PLAS MOLD #	PICTURE	LEN.	HT.	PROJ.	UNIT	WEIGHT
PLAS 886		77.75"	4-3/8"	4-3/8"	EACH	30 LBS
PLAS 889		43.5"	12"	6-1/8"	EACH	35 LBS
PLAS 890		82"	7-3/8"	3-1/8"	EACH	30 LBS
PLAS 891		78"	4-1/2"	10"	EACH	

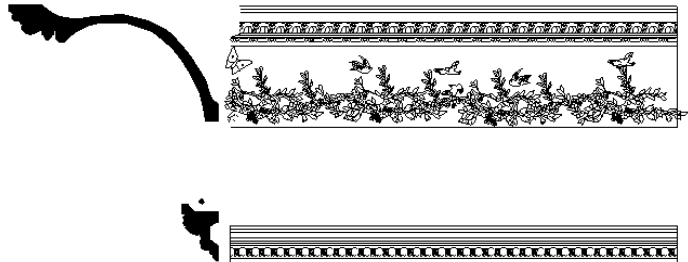

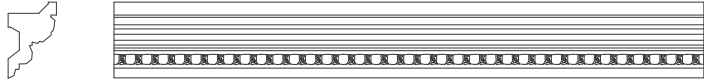
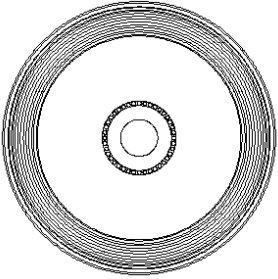
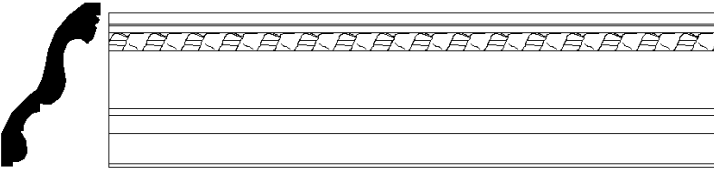
PLAS MOLD #	PICTURE	LEN.	HT.	PROJ.	UNIT	WEIGHT
PLAS 892					EACH	550 LBS
PLAS 893		93"	2"	7"	EACH	38 LBS
PLAS 894		14"	8-3/4"	9-1/2"	EACH	20 LBS
PLAS 895		96"	2"	7"	EACH	36 LBS

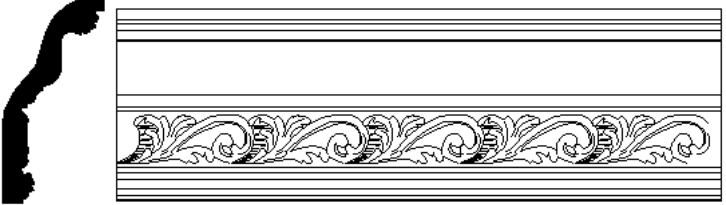
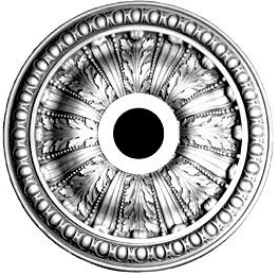
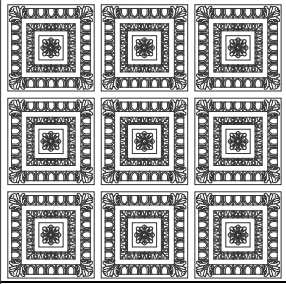
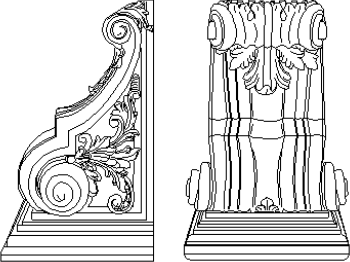
PLAS MOLD #	PICTURE	LEN.	HT.	PROJ.	UNIT	WEIGHT
PLAS 896		81"	7"	9"	EACH	50 LBS
PLAS 897					EACH	15 LBS
PLAS 898					EACH	25 LBS
PLAS 899		84"	12"	15-1/4"	EACH	80 LBS

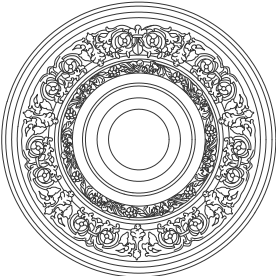
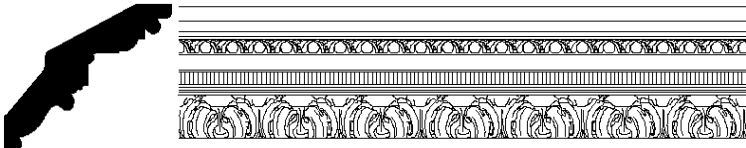
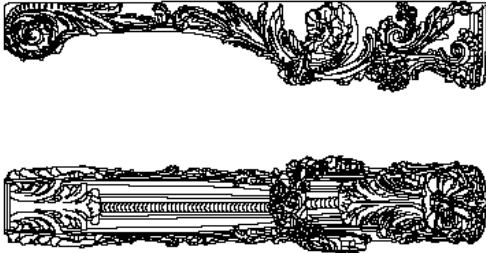
PLAS MOLD #	PICTURE	LEN.	HT.	PROJ.	UNIT	WEIGHT
PLAS 901					EACH	30 LBS
PLAS 902		90"	4-1/8"	2-5/8"	EACH	
PLAS 903		29-3/4"			EACH	30 LBS
PLAS 904		88"	5-3/4"	3-1/2"	EACH	35 LBS

PLAS MOLD #	PICTURE	LEN.	HT.	PROJ.	UNIT	WEIGHT
PLAS 905		89"	5"	2-1/2"	EACH	20 LBS
PLAS 906		29-3/4"			EACH	30 LBS
PLAS 908		40"	40"	3-1/2"	EACH	
PLAS 909		20-1/2"	13"	12"	EACH	20 LBS

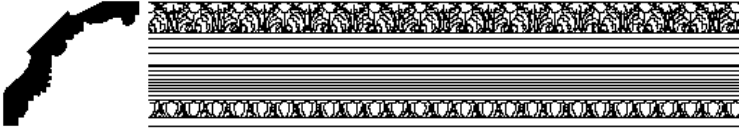
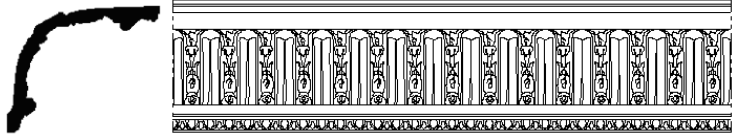
PLAS MOLD #	PICTURE	LEN.	HT.	PROJ.	UNIT	WEIGHT
PLAS 910		42"			EACH	60 LBS
PLAS 911		85.5"	5"	6-2/3"	EACH	30 LBS
PLAS 912		49"	10"	8-3/8"	PAIR	90 LBS
PLAS 913		90"	9-3/4"	5"	EACH	35 LBS

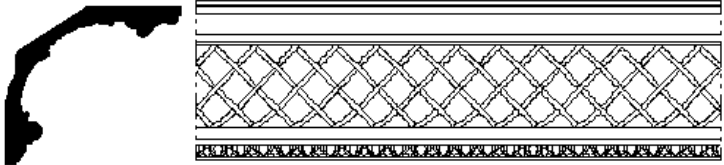
PLAS MOLD #	PICTURE	LEN.	HT.	PROJ.	UNIT	WEIGHT
PLAS 914		89"	5-1/2"	6"	EACH	
PLAS 915		85"	7-1/2"	9"	EACH	37 LBS
PLAS 916		84"	3-1/2"	4-1/2"	EACH	21 LBS
PLAS 917		90"	7-1/2"	9"	EACH	30 LBS

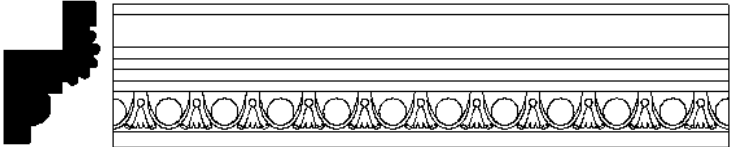
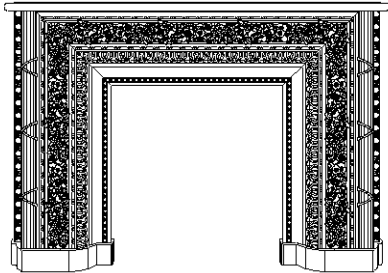
PLAS MOLD #	PICTURE	LEN.	HT.	PROJ.	UNIT	WEIGHT
PLAS 1015		96"	3-1/4"	2-1/4"	EACH	20 LBS
STN 892					EACH	1100 LBS